

# MWD – QDT(165°C) Battery Pack Specifications



## Directory

<b>I. Product Category and Model</b> -----	<b>2</b>
<b>II. Battery pack characteristics</b> -----	<b>2</b>
<b>III. Structure and Appearance</b> -----	<b>3-9</b>
<b>IV. Security features</b> -----	<b>10</b>
<b>V. Test</b> -----	<b>10-11</b>
<b>VI. Quality inspection</b> -----	<b>12</b>
<b>VII. Packaging labeling</b> -----	<b>12</b>
<b>VIII. Precautions</b> -----	<b>12-13</b>

# MWD – QDT(165°C) Battery Pack Specifications



## I. Product Category and Model

### I.I Category

High temperature type--sub-high temperature lithium-thionyl chloride battery pack

### I.II Product Model

MWD--QDT (165°C) 36V battery pack

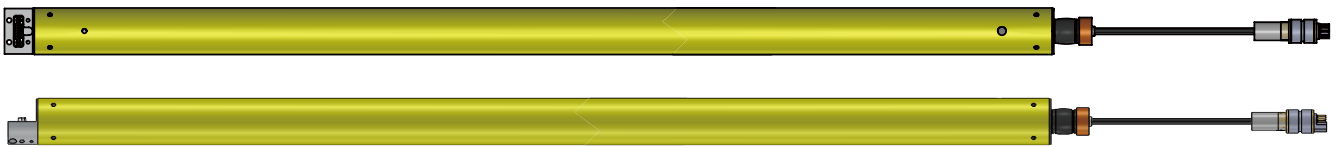

## II. General electrical performance

NO.	Project	Characteristic	Remark
1	Model	MWD-QDT (165°C)	-----
2	Nominal Voltage	36V	-----
3	Load Voltage	≥27.5V	750mA
4	Standard Discharge Current	400mA	-----
5	Nominal Capacity	28Ah	-----
6	Working Temperature	-20°C-165°C	Please contact the manufacturer for operating temperatures below -20°C or above 165°C
7	Maximum Dimensions/mm	φ37.5×1184	Not including leads (lead length 260mm)
8	Maximum Continuous Discharge Current	800mA	(120°C - 165°C environment)
9	Maximum Pulse Discharge Current	1400mA	(120°C - 165°C environment)
10	Weight	2.75kg	-----
11	Battery Pack Safety	Full diode insurance. Protection	Total Insurance: 5A; Single battery: 7A

# MWD – QDT(165°C) Battery Pack Specifications



## III. Structure and Appearance

### III.I Battery pack structure

Main materials of the battery pack: ER321270S (165°C) lithium battery, aluminum alloy tube or composite glass fiber tube, Teflon silver-plated wire, HL1910 circular special connector.

### III.I.I Basic performance of single ER321270S (165°C) lithium battery



**3.6V Li/SOCl<sub>2</sub> Battery**  
**Size: DD**  
**Middle C-Rate Type**  
**hi-temperature ER battery**  
**ER321270S-165**

## SPECIFICATIONS

(Typical data from the batteries stored at 25±5°C for 12 months)

**Nominal Capacity:** **28.0Ah**

(At 50mA, +25°C cut-off voltage 2.0V.)

**Open Voltage (at +25°C) :** **3.67V**

**Nominal Voltage (at +25°C, 0.3mA) :** **3.60V**

**Max. Continuous Discharge Current:** **1000mA**

(Obtained at +25°C~165°C, 50% nominal capacity, 2.0V cut-off voltage; For higher current, please consult POWERSTABILITY)

**Pulse Current:** **1500mA**

(at +25°C, the un-discharged battery starts to discharge with a base current of 1mA, the reading is still above 3.0V.)

**Storage (max.) :** **+30°C at most**

(please consult POWERSTABILITY for higher storage temperature requirements or stringent conditions)

**Working Temperature Range:** **-40°C - +165°C**

(exceeding the operating temperature range can result in reduced capacity, low voltage reading and low initial pulse voltage reading.)

# MWD - QDT(165°C) Battery Pack Specifications



## PHYSICAL PROPERTIES

<b>Diameter (max.):</b>	<b>34.5mm</b>
<b>Height (Max.):</b>	<b>124.5mm</b>
<b>Typical Weight:</b>	<b>208g</b>
<b>Lithium Metal Content:</b>	<b>(About)7.3g</b>

## ADVANTAGES

- Stable high operating voltage and high capacitance
- High energy density, high stable current
- Wide operating temperature ranges (-40°C ~ +165°C)
- Low self-discharge rate (annual self-discharge rate is less than 3% at +25°C)
- Excellent environmental application characteristics
- Stainless steel case (low magnetic resistance to environmental erosion)

## FEATURES

- A positive structure with proprietary technology
- Stainless steel - glass airtight package
- Non-combustible electrolyte
- High short circuit safety
- Comply with GB 8897.4-2008 technical requirements
- Meet technical requirements of IEC60086.4:2014

**Warning:** Do not charge, short circuit, heat more than 165°C, decompose, put into water, directly in the battery shell surface welding, otherwise may cause explosion, combustion and internal acid leakage of the battery.

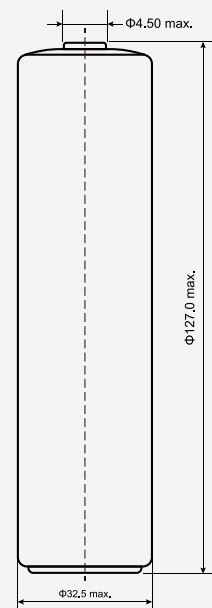

**Size unit :mm**  
(GB1804-m if tolerance is not specified)  
For special connection requests,  
please consult POWERSTABILITY

# MWD - QDT(165°C) Battery Pack Specifications



## WARNING

- Do not short out the battery
- Do not charge the battery
- Don't pin the batter
- Do not squeeze the battery
- Pay attention to the battery anode and cathode
- Electrical equipment connection is correct
- Do not disassemble the battery
- Do not burn batteries
- Do not mix old and new batteries
- Do not heat the battery to more than 165°C
- Do not directly weld the battery
- Please use a battery with pre-welded pins or wires.

**Notice:**  
POWERSTABILITY reserves the right to change the information contained in this data sheet without prior notice. Any performance parameters mentioned in this file are for reference only, and the contents of this document can be used as valid contract data only after written confirmation by both parties.

### 1. Voltage VS Capacity at +135°C (intermediate value)

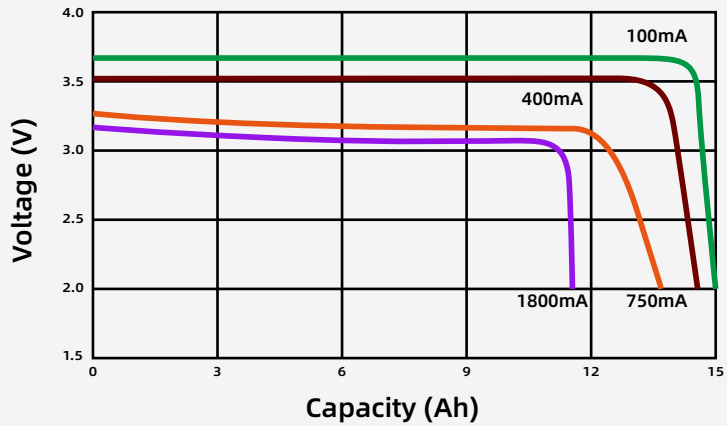

### 2. Current VS Temperature

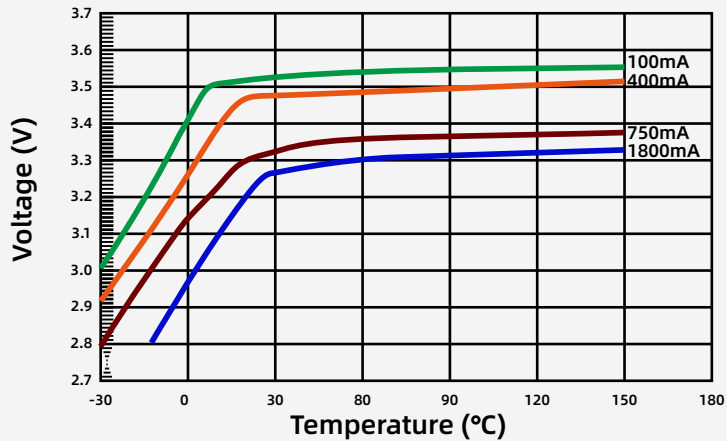

### 3. Capacity VS Temperature (cut off at 2.0V)

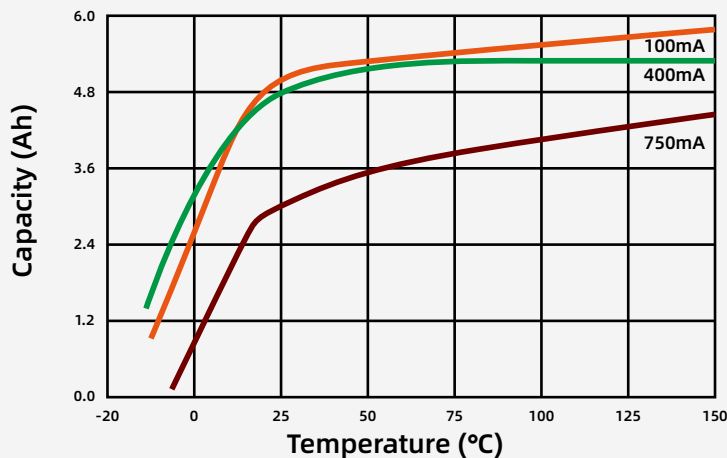

# MWD – QDT(165°C) Battery Pack Specifications



## III.I.II Capacitor discharge test

### III.I.II.I Rated capacity test

Put the battery in a test environment of 165°C for 12 hours, discharge it with a standard discharge current of 200mA constant current to a cut-off voltage of 2.0V, or connect a 17200mΩ load and discharge continuously until the battery voltage reaches a cut-off voltage of 2.0V.

### III.I.II.II Rapid discharge capacity test

Put the battery in a test environment at 165°C for 12 hours, discharge it with a constant current of 1200mA to a cut-off voltage of 2.0V, or connect a 2900mΩ load and discharge continuously until the battery voltage reaches a cut-off voltage of 2.0V.

### III.I.II.III Storage and capacity

After the battery is stored at 60°C for 28 days, it is placed in a dry place at 25±5°C for 4 hours, and the discharge capacity test is carried out according to the rated capacity test method in III.I.II.I

## III.I.III Seismic performance

Vibrate the battery with a simple harmonic vibration with an amplitude of 0.8 mm (maximum double amplitude of 1.6 mm). The initial vibration frequency is 15Hz-1000Hz-15Hz, the reciprocating time is 60m, the acceleration is 200m/s<sup>2</sup>, and the vibration is one cycle.

## III.I.IV Quality Consistency Inspection

The quality consistency inspection is used to judge whether the battery is qualified in the production process and to ensure the stability of product quality. Can refer to GB/T8897.1-2013, GB8897.2-2013 standard implementation.

## III.II Characteristics of HL1910 circular special connector

### III.II.I Conditions of use

Operating emperature	Working Pressure	Relative Humidity	Vibration	Impulse
-40°C-125°C	0.1Mpa-80Mpa	90-95% at 40°C ±2°C humidity	10-1000Hz acceleration 196m/s <sup>2</sup>	480m/s <sup>2</sup>
165°C for a short time	Short time 100Mpa			

# MWD - QDT(165°C) Battery Pack Specifications

### III.II.II Main technical indicators

Working Current	Contact Resistance	Insulation Resistance	Dielectric Strength	Life
5A	≤10mΩ	normal atmospheric conditions ≥1000mΩ, high temperature environment ≥200mΩ, after humidity test ≥10mΩ	Voltage 500Vac after 250Vac test	1000 times

### III.II.III Structure diagram of HL1910 circular special connector

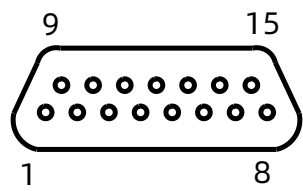
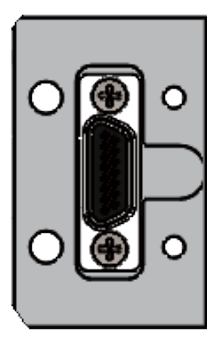
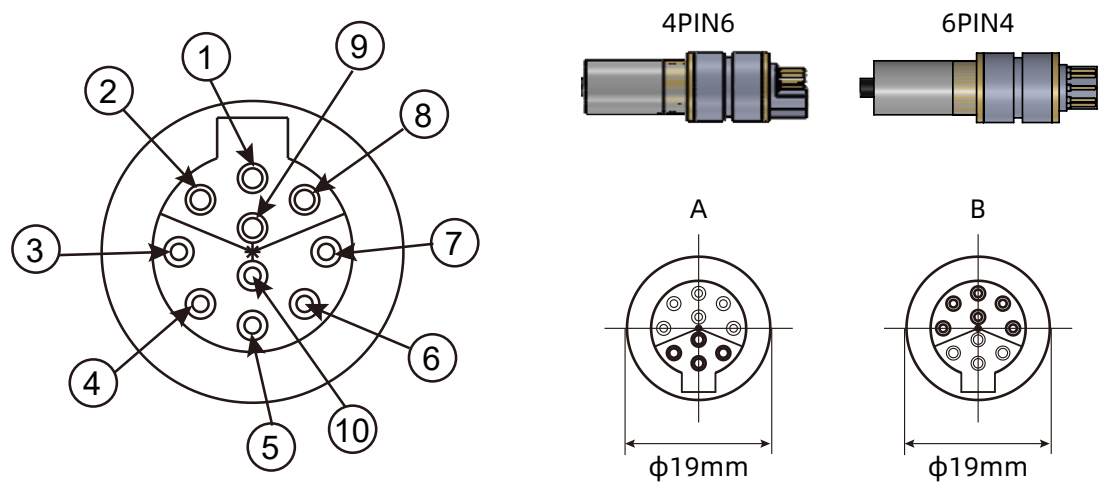

**MDM 15 Socket  
Mating View**

# MWD - QDT(165°C) Battery Pack Specifications

### III.III Basic dimensions and structure diagram of the battery pack

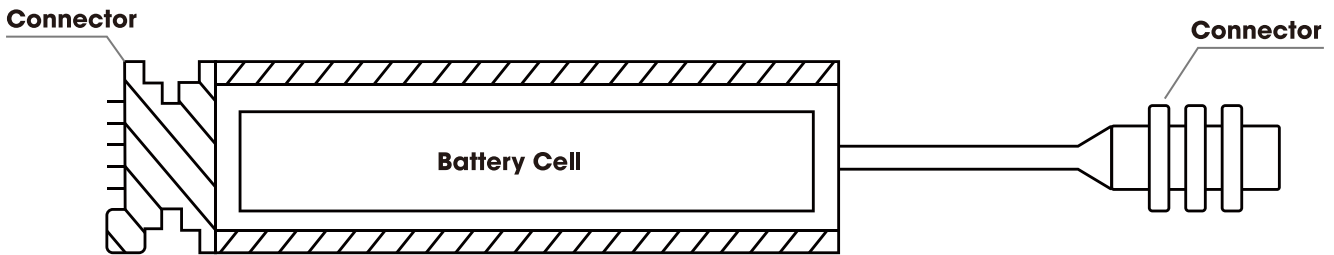

### III.IV Basic electrical diagram of battery pack

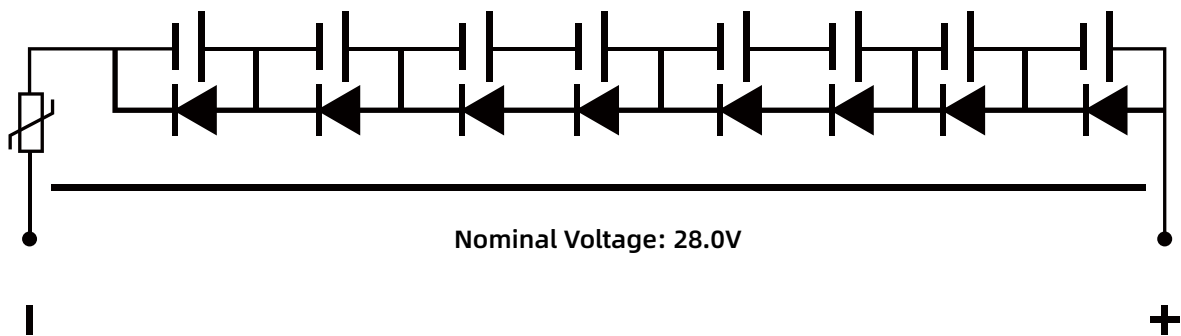

### III.V Communication Connection Diagram of Battery Pack Connector





# MWD - QDT(165°C) Battery Pack Specifications

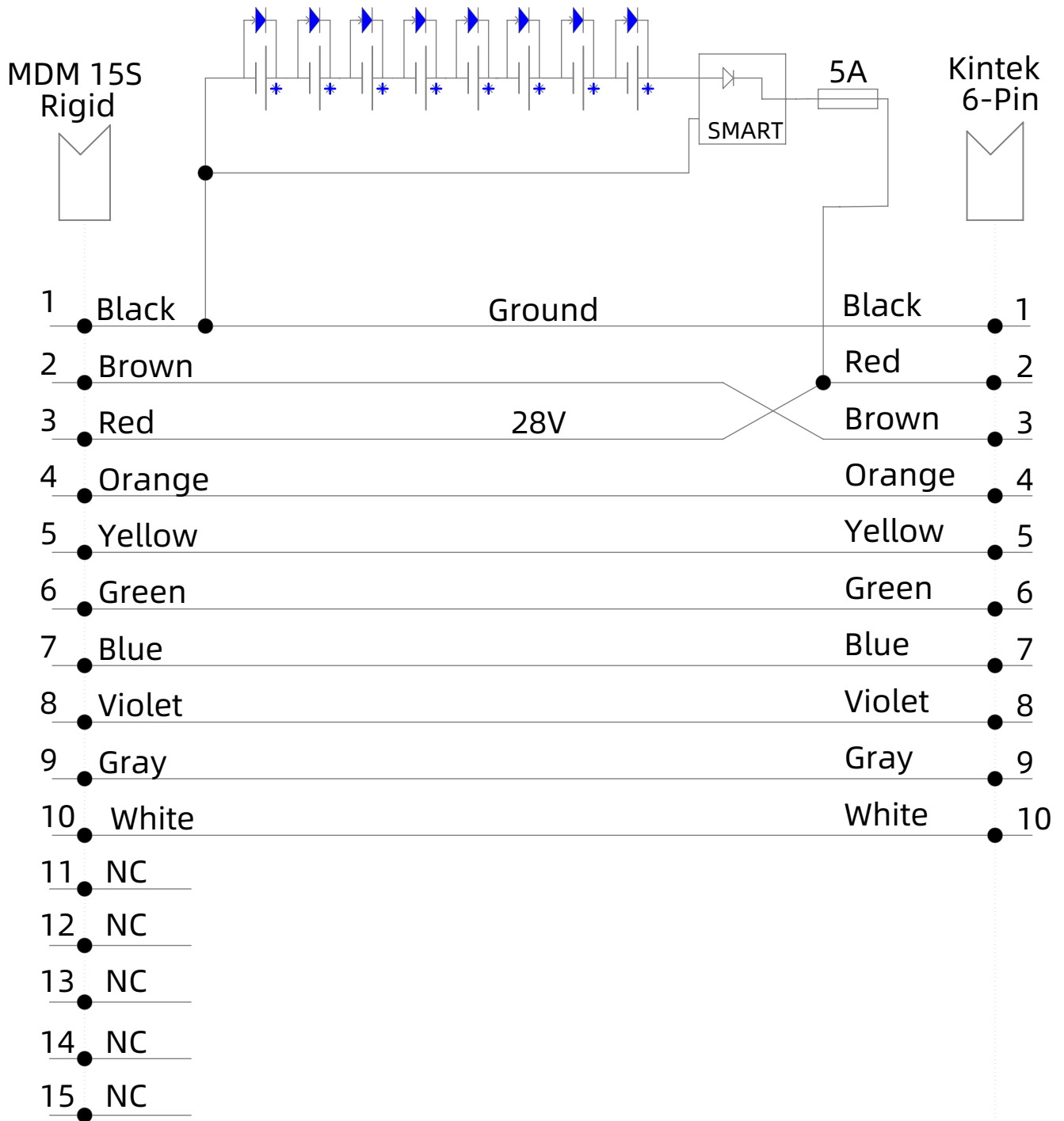

# MWD – QDT(165°C) Battery Pack Specifications



## IV. Security features

No.	Project	Judgement Standard	Test Methods
1	Seismic performance	No explosion, no fire, no leakage	
2	Leakproof performance	No explosion, no fire, no leakage	
3	Insulation properties	No explosion, no fire, no leakage	
4	Continuity test	smooth communication	

## V. Test

### V.I Test conditions and instruments

#### V.I.I Standard test environment

Unless otherwise specified, the standard conditions for detection are:  
Temperature: 120°C-165°C, relative humidity: 40±5%, atmospheric pressure: 90±10Kpa

#### V.I.II Test time

Testing should be done within one month of delivery.

#### V.I.III Measuring instruments

- (1) The voltage measurement is carried out with a voltage with an accuracy of not less than 0.5, an accuracy of 0.01V, and an internal resistance of 10MΩ or more.
- (2) The length of the battery pack shall be measured with a meter ruler with an accuracy of no less than 1mm, and the diameter shall be measured with a vernier caliper with an accuracy of no less than 0.02mm.

### V.II Test method

#### V.II.I Open circuit voltage

Store the battery pack sample in the standard environment of V.I.I, and then use the voltmeter specified in V.I.III (1) to measure the voltage between the positive and negative electrodes of the battery pack at the same temperature. The voltage value should be 28.5-29V. (Any short circuit will cause the open circuit voltage of the battery to drop or cause the total fuse of the battery pack to break, resulting in no voltage)

# MWD – QDT(165°C) Battery Pack Specifications



## V.II.II Load voltage

Place the battery pack in the standard environment of V.I.I for 30 minutes, discharge it with a load of 200mA for 5 minutes, and measure the voltage between the two poles of the battery with the voltage specified in V.I.III (1). The voltage is not lower than 20V.

NOTE: If you do not plan to use the new battery immediately, do not load it, because loading will cause the battery to discharge, thereby reducing the life of the battery.

## V.II.III Leakage performance

Vibrate the battery, the initial vibration frequency is 10Hz-1000Hz-10Hz, the reciprocating time is 60min, the acceleration is  $196\text{m/s}^2$ , and the vibration is 1 cycle.

## V.II.IV Insulation properties

Use a  $20\text{M}\Omega$  multimeter to point the 1-10 pins of the battery pack connector and the outer wall of the battery pack, point the black pen on the 1 pin of the connector, and point 2, 3, 4, 5, 6, 7, 8, 9, 10 with the red pen to the outer wall. And so on black pen to the outer wall. Between the needles and the outer wall  $\geq 20\text{M}\Omega$ .

## V.II.V Continuity test

1. Connect the component detectors to both ends of the battery cartridge, and set the switches to the "off" position;

2. Put the multimeter on the bell ohm range, measure the resistance between the "lower 1" and "upper 1" sockets, the reading value should be less than 1 ohm, and you can hear the beep;

3. Measure "upper 2" and "lower 2", then "upper 3" and "lower 3", "upper 4" and "lower 4", "upper 5" and "lower 5", "upper 6" and "lower 6", "upper 7" and "lower 7", "upper 8" and "lower 8" should be less than 1 ohm, which is in the conduction state;

4. Note: Do not measure the resistance between 1 and 2 (there is battery voltage between them), otherwise there will be potential danger!

## V.II.VI Dimensions

Under the test conditions of the standard test environment in V.I.I, use the test equipment in V.I.III (2) to test the battery dimensions.

# MWD – QDT(165°C) Battery Pack Specifications



## VI. Quality inspection

Quality inspection is used to determine whether the battery pack is qualified to ensure the stability of product quality during the production process, and can refer to GB/T8897.1-2013, GB8897.2-2013 standards for implementation.

## VII. Packaging labeling

Based on the agreement between the supplier and the buyer, it is packaged according to the prescribed method. Put the packing list and inspection report in the packing box, and the battery pack is affixed with the certificate of conformity, warnings, user records, and the production date will be marked on the tube wall of the battery pack.

## VIII. Precautions

MWD-QDT (165°C) battery pack is produced with unique technology and has certain safety, but as a lithium battery pack, it has certain dangers when it is damaged by electrical function or mechanical function like other battery packs. The MWD-QDT (165°C) battery pack must comply with the following regulations during storage, transportation and use.

### VIII.I Storage

MWD-QDT (165°C) battery packs should be stored in a cool, clean and dry environment, the recommended temperature is 10°C-30°C, and the relative humidity is  $\leq 50\%$ . Avoid contact with corrosive substances, keep away from fire sources and heat sources above 165°C.

**Battery storage should strictly abide by the following items:**

- ◆ Do not expose the battery to an environment higher than 165°C.
- ◆ Store the battery pack in its original packaging to eliminate any possible external short circuit.
- ◆ Do not store battery packs in conductive antistatic bags or foam.
- ◆ Do not place the battery pack on a conductive metal surface.
- ◆ Do not stack batteries together.

### VIII.II Transportation

The battery is in a fully charged state when it leaves the factory. During transportation, it should be packed into a box to prevent severe vibration, impact and extrusion, and prevent the sun and rain. It should be used in ordinary transportation such as cars, trains, ships, and airplanes.

# MWD – QDT(165°C) Battery Pack Specifications



## VIII.III Safe use

When using the MWD-QDT (165°C) battery pack, strictly abide by the following regulations to avoid improper operation. This can cause the battery to swell, leak, severely rupture, or even explode.

- ◆ It is strictly forbidden to short circuit between the positive and negative poles of the battery pack, charge and reverse the positive and negative poles;
  - ◆ It is strictly forbidden to over-discharge, squeeze, puncture and burn the battery;
  - ◆ Do not mix old and new battery packs with other types of battery packs;
  - ◆ Do not use the battery in an environment outside the allowable temperature range;
  - ◆ Before using the lithium battery pack, you should read the instructions and warnings in detail, operate strictly according to the regulations, and strictly prohibit exceeding the rated indicators;
  - ◆ Before the instrument is assembled, the appearance inspection of the battery pack must be done to ensure that there is no damage affecting the performance of the battery pack. There must be no rust, dirt, damage, etc. on the wires and connectors that may cause short circuit or open circuit. Once found, stop using it. And notify professionals to handle it;
  - ◆ The protective cap of the plug should be kept properly so that it can be used when the battery pack is temporarily not used or the old battery is recycled for storage and transportation;
- The use of lithium battery packs should be recorded as a basis for continued use;
- ◆ During the assembly of the lithium battery pack, never short-circuit the two ends of the battery pack. The short circuit of the lead wires and plug contacts of the battery pack may cause the internal fuse to blow. In the event of a battery failure, do not take it lightly;
  - ◆ When the batteries are used to the end voltage, they should be taken out of the instrument in time, and returned to the manufacturer's company in batches for disposal.